

GEOTRIT

Macerating pumping system



Construction

This macerating pumping system has been designed to pump away the waste water from a WC and a washbasin. It is possible to use it to add a new cloakroom, washroom or toilet, in a basement or loft conversion or anywhere conventional large bore pipework is impractical. The GEOTRIT macerating system is installed in a case specifically designed for horizontal outlet spigots. Installed and used correctly, this unit will give consistent and reliable service. The system has a grinder pump, clapet valve and carbon filter. GEOTRIT is provided with flexible sleeves, elbow, metal hose clips.

Operating conditions

- Voltage: 220-240 V
- Frequency: 50 Hz
- Degree of protection: IP44
- Maximum power rating: 400 W
- Maximum current consumption: 1,9 A
- Vertical pumping: max. 4 m
- Liquid temperature up to 35 °C

Application

GEOTRIT takes waste from :



WC



Washbasin

Characteristic curve

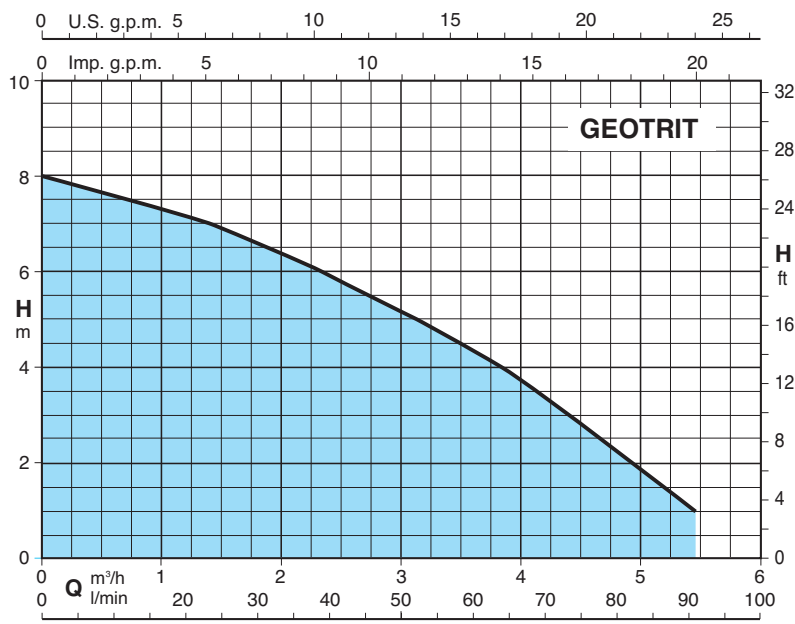

Q	m ³ /h	0	1,2	2,4	3,6	4,8	5,4
	l/min	0	20	40	60	80	90
H	m	8	7,1	5,9	4,3	2,2	1,1

Installation

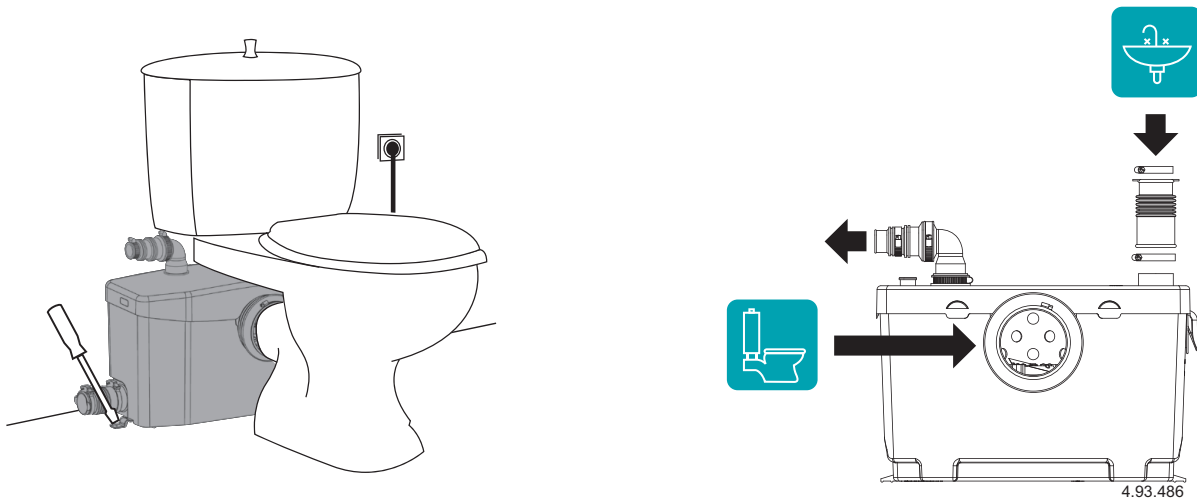

Performance

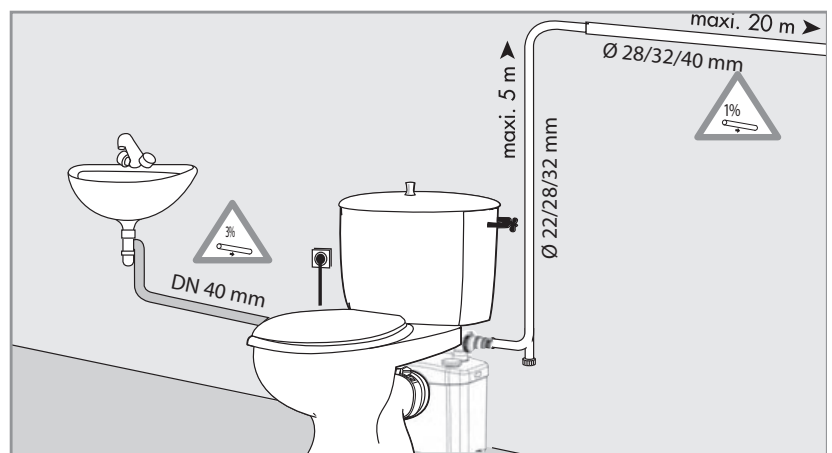
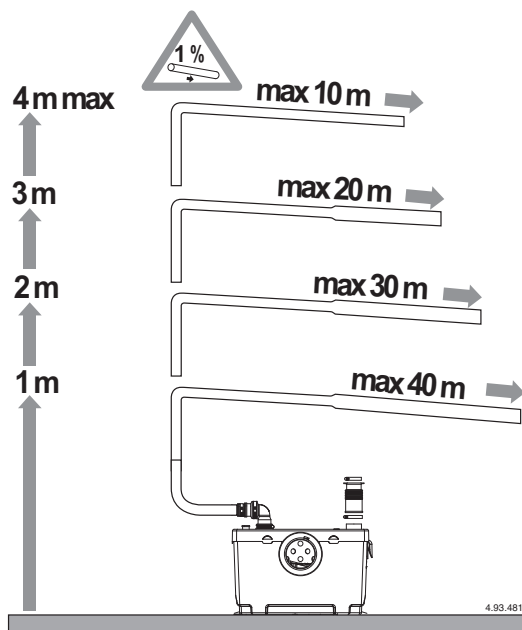

Dimensions and weights

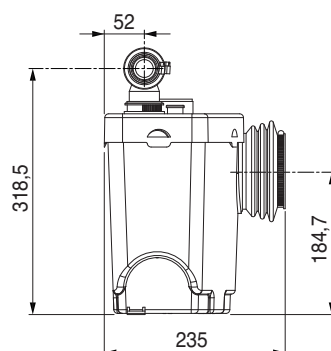
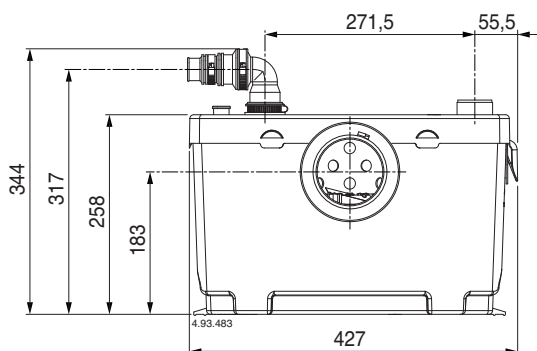

peso: kg 6,6

GEOCOMP

Macerating pumping system



Construction

This macerating pumping system has been designed to pump away the waste water from WC, washbasin, bidet and shower. It is possible to install a complete bathroom in a basement conversion or loft extension.

The GEOCOMP macerating system is installed in a case specifically designed for horizontal outlet spigots.

Installed and used correctly, this unit will give consistent and reliable service.

The system has a grinder pump, clapet valve and carbon filter. GEOCOMP is provided with flexible sleeves, elbow, metal hose clips.

Operating conditions

Voltage: 220-240 V

Frequency: 50 Hz

Degree of protection: IP44

Maximum power rating: 400 W

Maximum current consumption: 1,9 A

Vertical pumping: max. 4 m

Liquid temperature up to 35 °C

Application

GEOCOMP takes waste from :



WC



Washbasin



Bidet



Tube



Shower

Characteristic curve

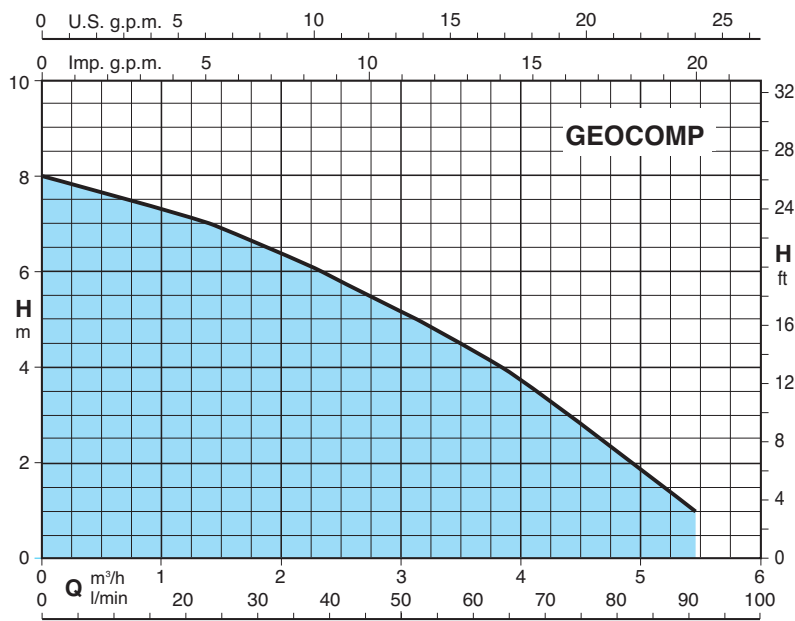

Q	m ³ /h	0	1,2	2,4	3,6	4,8	5,4
	l/min	0	20	40	60	80	90
H	m	8	7,1	5,9	4,3	2,2	1,1

Installation

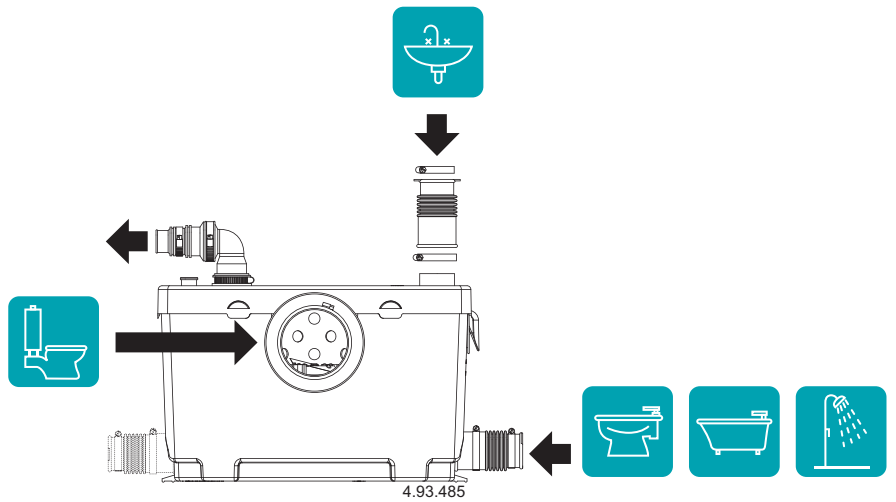
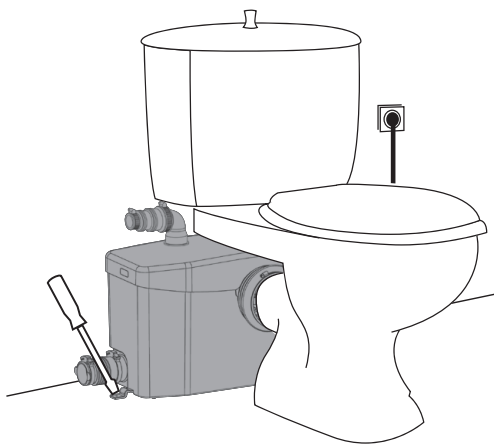

Performance

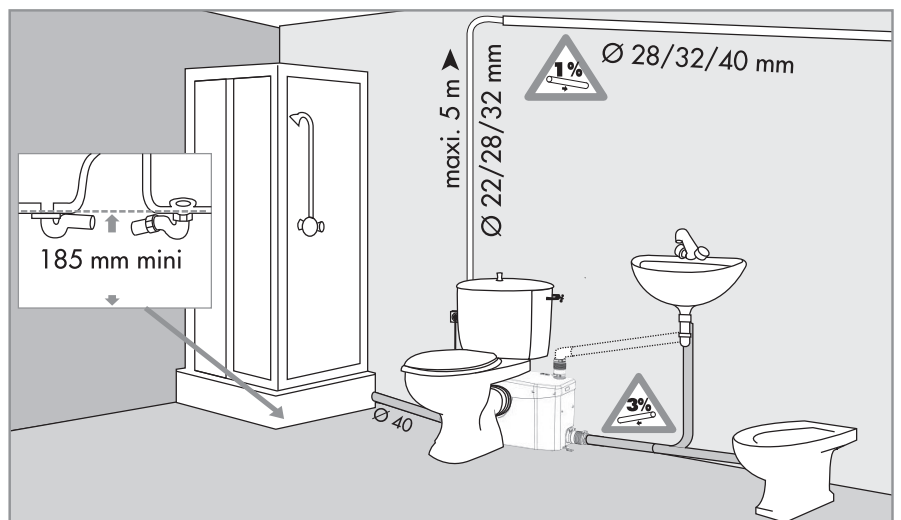
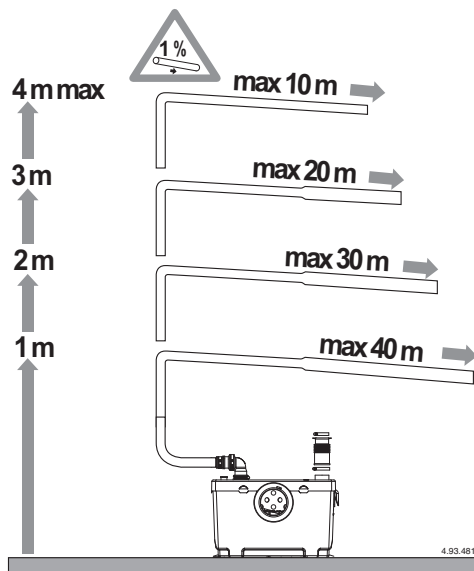

Dimensions and weight

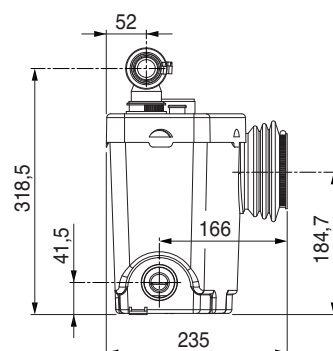
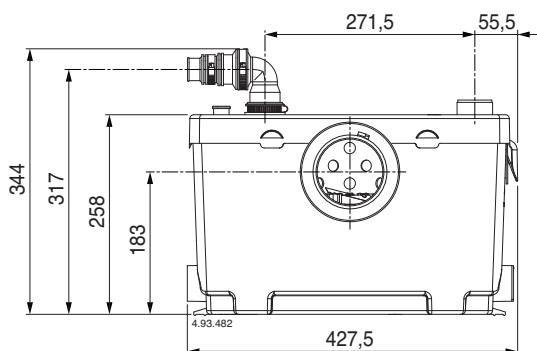

weight: kg 6,8



Construction

The system is design to handle the evacuation water from a domestic kitchen sink, dishwasher and washing machine – all working at the same time if required.

GEOCLEAN makes the addition of a domestic kitchen or utility room easy even when below or distant from a drain.

The system has a clapet valve and it cannot be used with waste waters.

GEOCLEAN is provided with flexible sleeves, elbow, metal hose clips, plugs.

Operating conditions

Voltage: 220-240 V

Frequency: 50 Hz

Degree of protection: IP44

Maximum power rating: 400 W

Maximum current consumption: 1,9 A

Vertical pumping: max. 5 m

Liquid temperature up to 60 °C

Application

GEOCLEAN takes waste from :



Washbasin



Bidet



Tube



Shower



Kitchen sink



Dishwasher



Washing machine

Characteristic curve

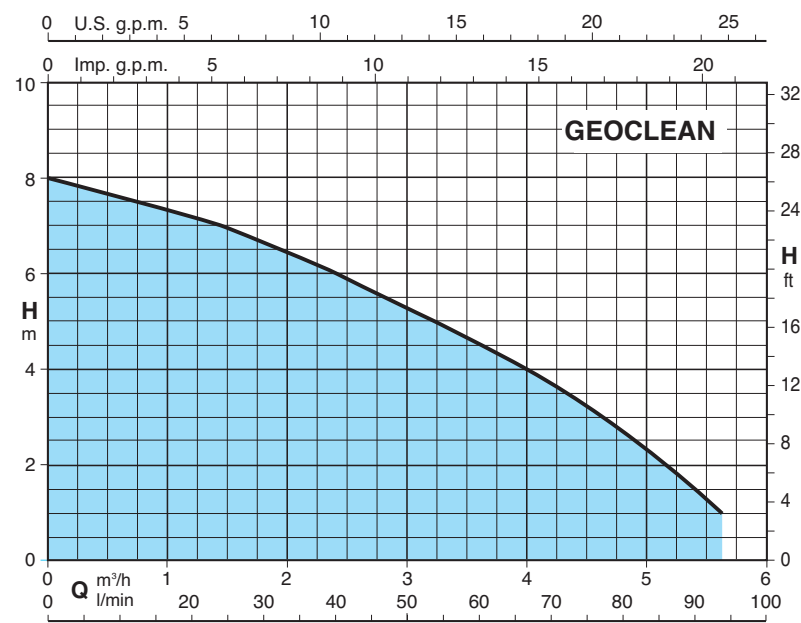

Q m ³ /h	0	1,2	2,4	3,6	4,8	5,6
l/min	0	20	40	60	80	93
H m	8	7,1	5,9	4,5	2,7	1

Installation

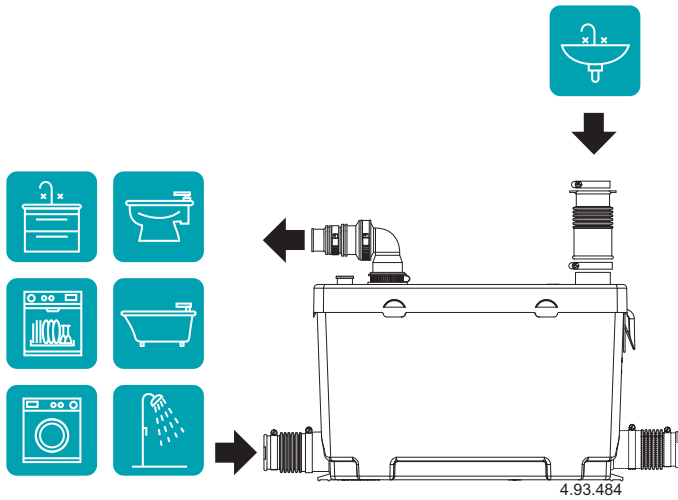

Performance

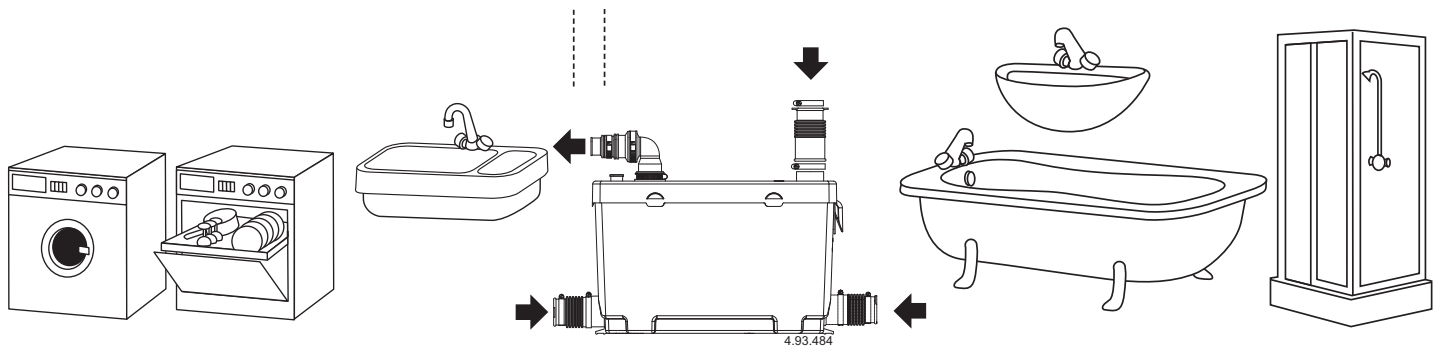
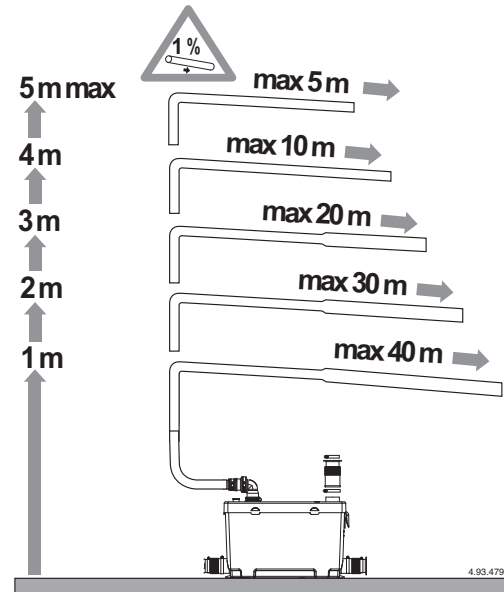

Dimensions and weight

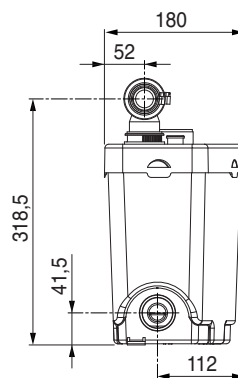
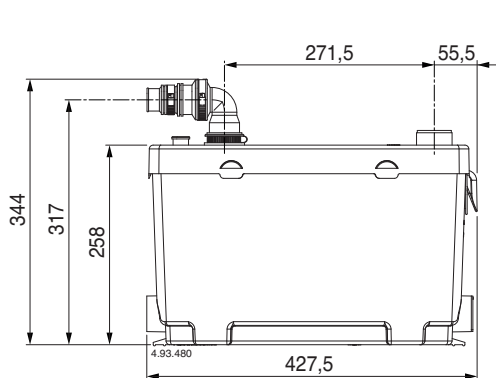

weight: kg 6,4