

NCE EL Energy saving circulating pumps for solar systems



Construction

Energy saving variable speed circulating pump driven by a permanent magnet synchronous motor (pm) controlled by on board inverter.

Applications

Solar thermal systems.

Operating conditions

- Liquid temperature from +2 °C to +110 °C
- Ambient temperature from 0 °C to +40 °C
- Maximum permissible working pressure: 10 bar
- Storage: -20°C/+70°C max. relative humidity 95% at 40 °C
- Certifications: in conformity with CE requirements
- Sound pressure: ≤ 45 dB(A).
- Minimum suction pressure:
 - 0,3 bar at 50 °C
 - 1,0 bar at 95 °C
 - 1,5 bar at 110 °C
- Maximum glycol quantity: 40%
- EMC according to: EN 55014-1, EN 61000-3-2, EN 55014-2
- Connections: threaded ports ISO 228: G 1, G 1 1/2.
- The benchmark for most efficient circulators is $EEL \leq 0,20$.
- Minimum power: 3 W.

Motor

Synchronous motor with permanent magnet.

- Motor: variable speed
- Standard voltage: single-phase 230 V (-10%;+6%)
- Frequency: 50-60 Hz
- Protection: IP 44
- Insulation class: H
- Class II appliance
- Overload protection (jammed rotor):
 - 1) automatic protection with electronic rotor release
 - 2) Overload thermal protector
- Cable: phases and neutral
- Constructed in accordance with: EN 60335-1, EN 60335-2-51.

Special features on request

Brass or cast iron unions.

Designation

NCE EL 25 - 60 / 180

Series _____
 Version _____
 DN ports in mm _____
 Max. head in dm _____
 connection size mm _____

Features

Compact design

The space saving **NCE EL** is a very compact circulating pump, allows inr easy installation in small domestic heating systems.

Easy to install and to adjust

Installing the **NCE EL** is considerably simplified by the quick setting and power installation plug.

Reliable

Like all our electronic circulating pumps, the **NCE EL** features the patented self-cleaning square chamber design, which eliminates any possibility of rotor blockage.

Ceramic shaft.

Hydraulics components are completely painted with cataphoresis.

Program for automatic routine vent and release.

Easy use

Operating range with fixed curves from 0,6 m to 7 m; possibility to choose proportional pressure curve or selection of the optimum working point.

Operating modes



PROPORTIONAL CURVE PROGRAMMING $\Delta p-v$ (GREEN LED)

Moving the switch to the 'P' setting will allow the pump to operate against a proportional performance curve. This feature ensures maximum energy efficiency.



MANUAL PROGRAMMING (BLUE LED)

Setting the switch in any position between the MIN and MAX points, the most suitable operating curve for the installation is manually selected.

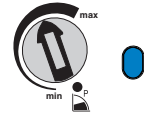

WARNING!



- The red LED indicates that the pump is not rotating but is still under tension.
- White flashing LED : plant degassing requirement, air in the system.

Characteristic curves

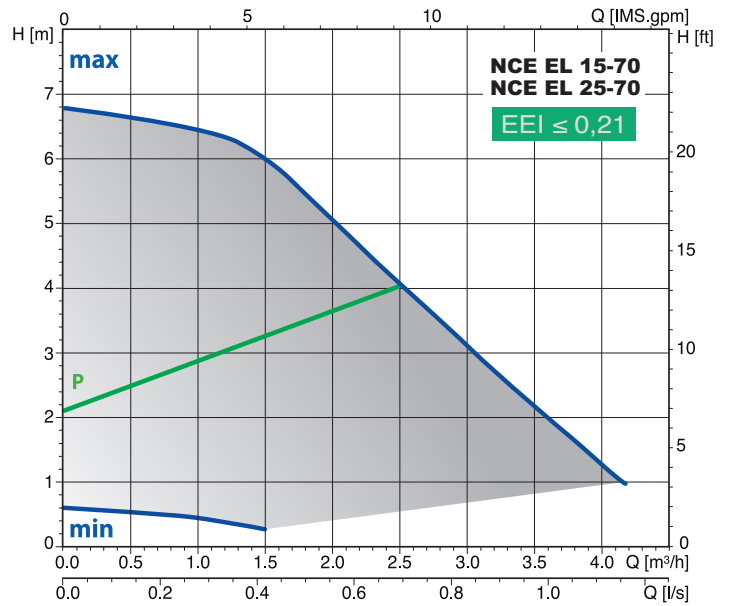
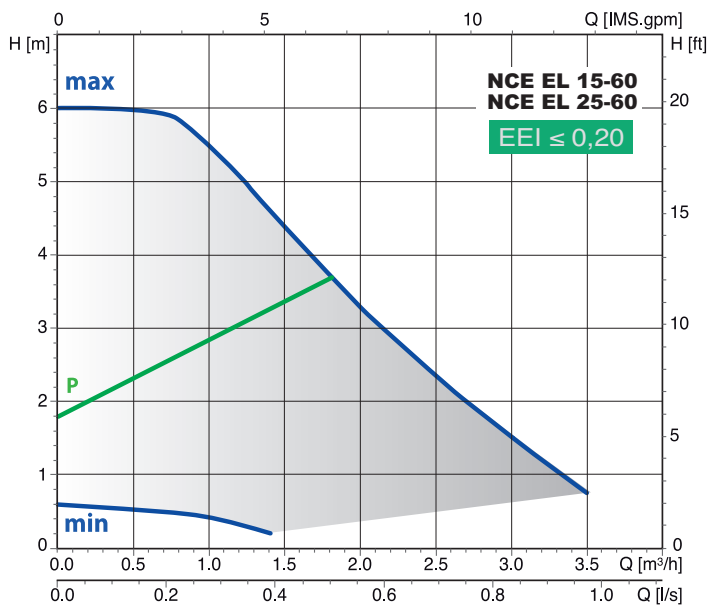

P proportional curve
min-max n fixed curves

Materials

Component	Pos.	Material
Pump casing	1	Cast iron GJL 200 EN 1561
Impeller	2	Composite
Shaft	3	Ceramic
Bearings	4	Carbon
Thrust bearing	5	Ceramic
Rotor	6	Composite / Ferrite
Winding	7	Copper wire
Electronic card	8	-
Gasket	9	EPDM

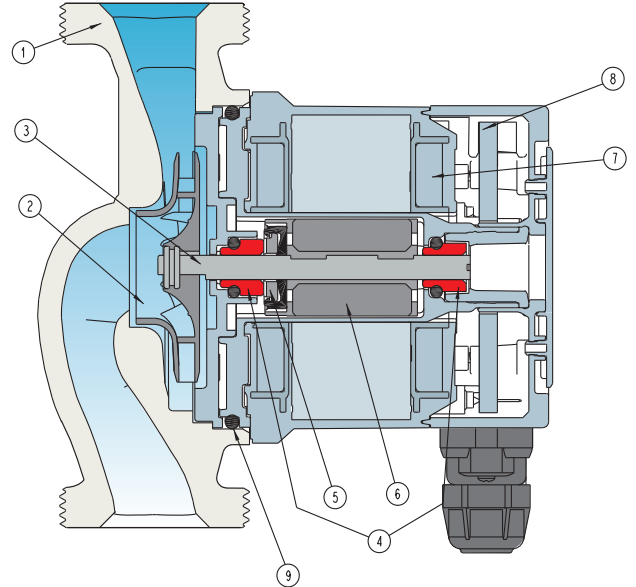

Dimensions and weights

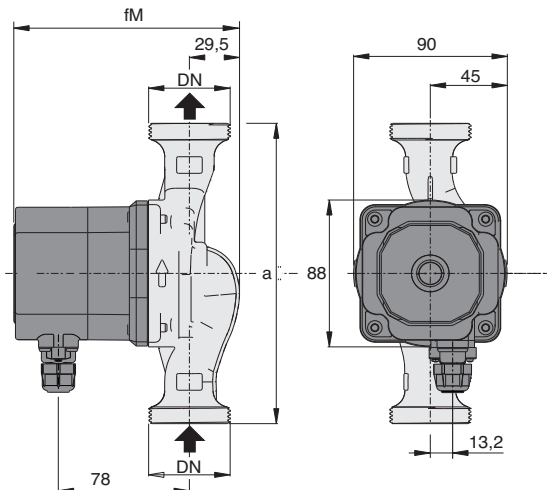

TYPE	DN	230V		P1		mm		kg
		A max	A min	W max	W min	fm	a	
NCE EL 15-60/130/A	G 1	0,33	0,03	42	3	134	130	1,67
NCE EL 25-60/130/A	G 1 1/2						1,81	
NCE EL 25-60/180/A	G 1 1/2	0,33	0,03	42	3	134	180	1,96
NCE EL 15-70/130	G 1	0,44	0,03	56	3	144	130	1,91
NCE EL 25-70/130	G 1 1/2						2,05	
NCE EL 25-70/180	G 1 1/2						2,20	

Unions (on request)

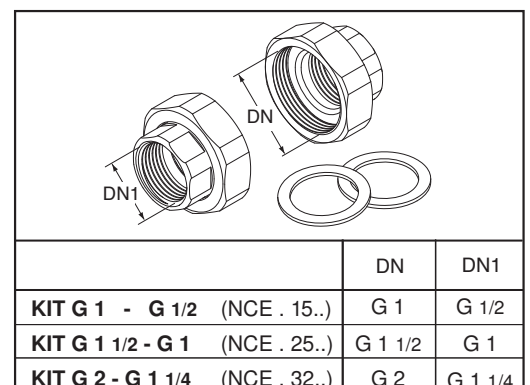

Examples of installations

Installation

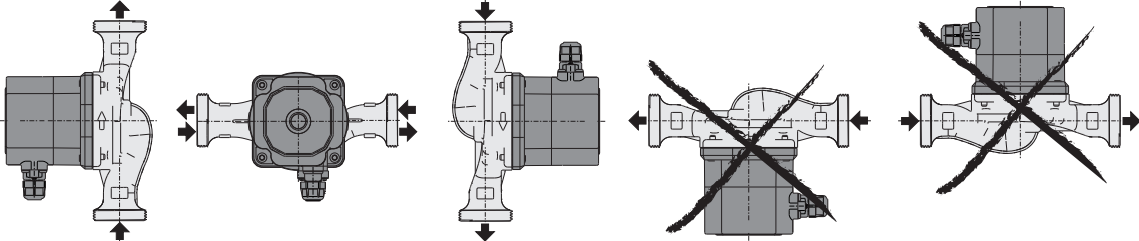

Terminal box arrangement (on request)

